

# The LETTER LOK 3000 Return Fastener

**Designed to fasten the open ends of channel letter returns up to a combined thickness of 0.160" in aluminum.**

The LETTER LOK 3000 Return Fastener is an air over oil powered clinching machine featuring a one-piece steel frame with a 3 1/2" throat.

This time saving machine eliminates drilling and pop riveting open letter returns and letter centers. Installed with Chief Enterprises special tooling\* this versatile fastening machine can produce a UL recognized fastener in two pieces of aluminum.

The LL3000 is nearly maintenance free and is supplied with a #40 die and comes complete with a spring balancer for mounting to our optional mobile cart or a customer supplied fixture. Unpacking and attaching a 3/8" air line is all that is required for set-up.

The LL3000 is a portable machine and can be used for fastening applications in any area where you have access to a 3/8" air line and 80 pounds of air pressure.

\* Chief Enterprises part #MP70001, #MP70002 and #MP70010.

## LL3000 Mobile Cart

**This cart is perfectly balanced to carry the LETTER LOK 3000 Return Fastener.**

The optional Mobile Cart for the LETTER LOK 3000 Return Fastener is an all-steel welded cart designed to support the portable tool for easy locating and transportation in any plant environment.

The cart comes complete with 3" diameter locking casters, collapsible design for easy shipping and storage, mounting for power unit, and hooks for machine and hydraulic hoses.



THE COMPANY WITH NEW IDEAS



**CHIEF ENTERPRISES INC.**

922 N. Oaklawn Ave., Elmhurst, IL, USA, 60126-1018  
ph 800 831-7294 fx 630 530-1154  
email pnietzel@chiefent.com, slabarbera@chiefent.com  
web www.chief-mm.com

MANUFACTURED EXCLUSIVELY FOR  
CHIEF ENTERPRISES BY

**NORLOK**  
TECHNOLOGY INC.  
*Setting the standards*

**SPECIFICATIONS – LL3000 Return Fastener  
(Model – LL3000 MDWA)**

**Press Design:** Single steel "C" frame.

**Features:** Air over oil intensifier.  
**Single shot auto return.**

**Stroke:** 1/4"  
**Throat:** 3 1/2"  
**Work Height:** Not applicable

**Upper Tooling:** Fast change punch.  
Replaceable punch stripper.

**Lower Tooling:** MDWA insert style.  
Adjustable to suit material thickness.

**Capacity:** **MEDIUM DUTY (0.18"Ø PUNCH)**  
Aluminum:  
MAX: Combined thickness of 0.160"  
MIN: Two ply 0.024"

**Cycle speed:** 30 - 40 CPM (standard speed).

**Air Requirements:** 80 psi (min) 100psi (max)  
85 psi (recommended)  
Approx. 0.8 cu ft free air per cycle.  
(5 HP @ 40 clinches per minute)

**Dimensions:** Width 2-3/4" (overall)  
Length 13-9/16" (overall)  
Height 7-13/16" (overall)  
Weight 17 lbs (approx.)

**Options:** 7 ft tall mobile cart with 2 ft arm.

**Typical Joint Strengths (Aluminum)**

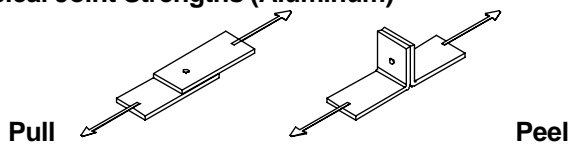

Material Thickness Punch side/ Die side	Pull (lbs)	Peel (lbs)
0.090" to 0.063"	240	95
0.080" to 0.080"	265	90
0.063" to 0.063"	240	72
0.063" to 0.040"	270	50
0.040" to 0.040"	175	60

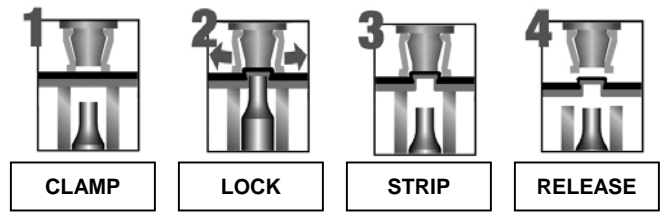

**LL3000 RF**

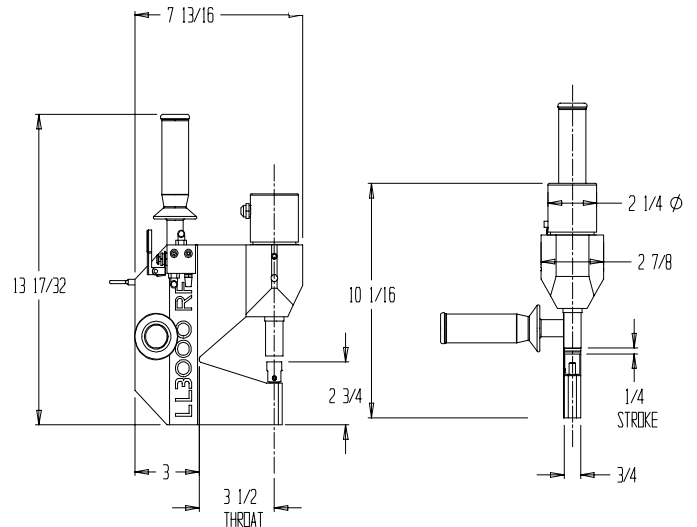

**Mobile Cart**

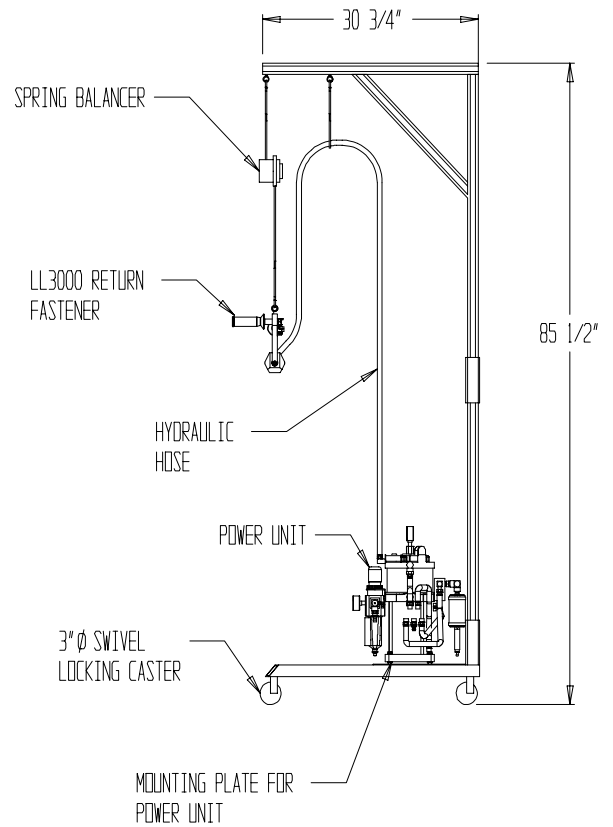

*The Company With New Ideas*

922 N. Oaklawn Ave  
Elmhurst, IL, USA, 60126-1018  
ph 800 831-7294 fx 630 530-1154  
email pnietzel@chiefent.com, slabarbera@chiefent.com  
web www.chief-mm.com