

Specifications

- 1 Open-height adjustment
- 2 Main operator valve
- 3 Press C-Frame
- 4 Filter/Regulator
- 5 Laser pointer
- 6 Multi-track pneumatic power unit
- 7 Safety stroke cover plate
- 8 Lexan guard
- 9 Punch
- 10 Die
- 11 Quick access control cover plate
- 12 Covered foot pedal
- 13 Air surge tank

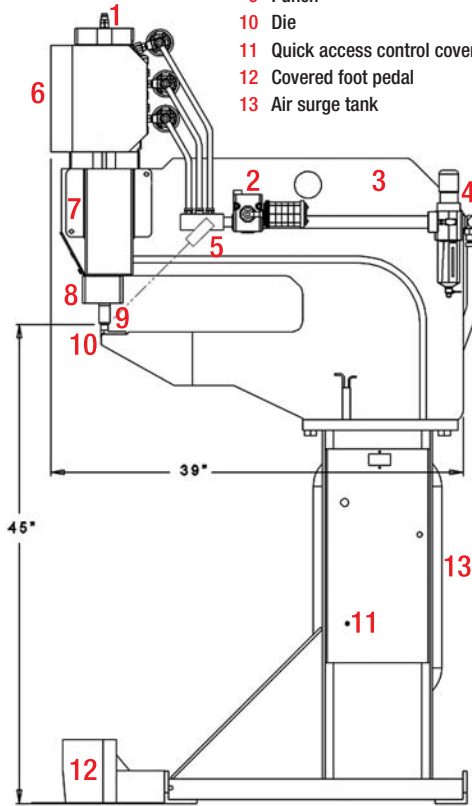

Material Specifications



Thickness (2 ply)	Die	Pull Strength (lbs)	Peel Strength (lbs)
0.022" (26g)	#30	285	70
0.028" (24g)	#30/#40	325	85
0.034" (22g)	#40	375	100
0.040" (20g)	#40/#50	400	120
0.052" (18g)	#50	430	150
0.063" (16g)	#50	475	175
0.075" (14g)	#50	775	220

What others say about the Surelok

I would like to take this opportunity to recommend the Surelok clinching machine to any college or technical school. The machine is safe, clean, easy to use and an excellent way of introducing the students to a new fastening technology. This is a wonderful piece of machinery, with great support and cutting edge technology.

Dan Nichols

Co-ordinator/Professor - Mechanical & Industrial Engineering

Mohawk College of Applied Arts and Technology

Fennell Ave and West 5th ST, PO Box 2034
Hamilton, Ontario, Canada L8N 3T2

The Surelok clinching machine is an excellent way to teach our students about the modern metal fastening technology of clinching. It is a safe, clean and easy for our students to operate. I would certainly recommend the Surelok clinching machine to any college or technical school.

Chris Vickers

Coordinator - Sheet Metal Department

George Brown College - "The City College"

160 Kendal Ave., Toronto, Ontario M5R 1M3



26 Adams Boulevard,
Brantford, Ontario, Canada N3S 7V2

519.759.5896

Fax: 519.759.2948

Email: info@norlok.com • Web: www.norlok.com

ISO 9001
REGISTERED COMPANY



A new generation of metal fastening

THE APPRENTICE

A NEW GENERATION of metal fastening

With its safe operation and innovative design the “Apprentice” by Norlok will introduce students to the modern technology of metal fastening by clinching.

Due to its reliability, low environmental impact and cost effectiveness, Clinching is the new and preferred method of fastening sheet metal in the 14 - 32 gauge range within many manufacturing and sheet metal industries.

Clinching is widely used in the HVAC, building, automotive, appliance, and furniture industries as well as window, swimming pool, garage door and trailer manufactures.

The “Apprentice” by Norlok is being chosen by Colleges and Technical schools throughout North America as an industrial standard clinching machine to give students the hands on training and experience they will need as they enter the world of metal working.

We offer educational material, training and installation (if required) as well as full after purchase technical and maintenance support.



CLINCHING... how does it work?

Clinching is a method of fastening sheet metal together without the need for heat, rivets, fasteners or adhesives.

To create the joint, a special punch and die, create a ‘mushroom-like’ lock from the base metals. It produces a virtually leak proof joint in materials as thick as 0.135” (3mm) and as thin as 0.010” (0.25mm)

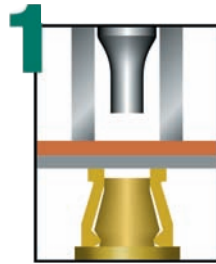

1 The tooling clamps the material between the punch and die.

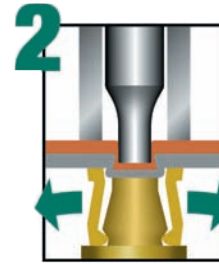

2 The punch pushes the material into the die which opens and forms a ‘mushroom’ lock.

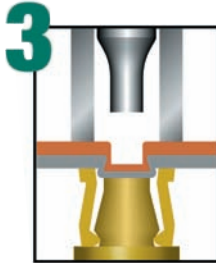

3 The punch is stripped out and the lock remains.

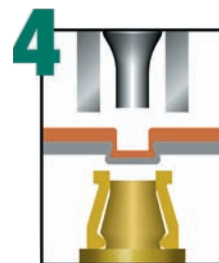

4 The tooling unclamps the material and the part is easily removed.

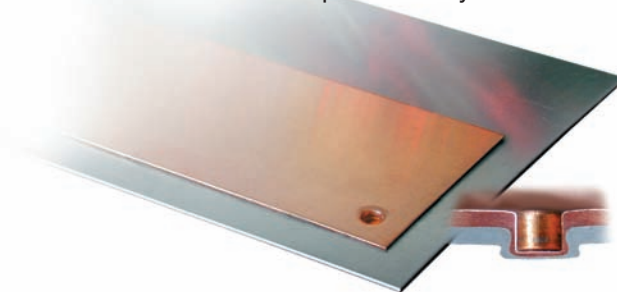

The APPRENTICE... because learning really works!

Operator safety

The “Apprentice” features a innovative “intelligent” safety stroke that allows a very low force tooling approach stroke. This eliminates the risk of operator injury during the clinching cycle.

Easy to operate

The “Apprentice” is easy to set up and operate, requiring little initial training and supervision. The machine features automatic cycle return and a low power class II laser pointer for accurate locating of parts.

Clean - environmentally friendly

The “Apprentice” is air powered, and produces no toxic fumes, sparks or heat. Minimal safety equipment is required.

New technology

The “Apprentice” is state of the art technology - this is the equipment your students will find when they enter an industrial environment.

Teaching aids available

Norlok Technology can supply teaching aid to help introduce the students to this technology as well as web site support. Contact us for more information on our expanding range of aids.

Small footprint

The “Apprentice” has a small footprint, taking up little floor space. Being air powered it is always available for immediate use.

Affordable

Every thing required to set up and operate the machine is included in the initial cost. This machine has been designed and featured specifically for use in colleges and trade schools.

NORLOK
TECHNOLOGY INC.

Setting the standards

for a new generation of metal fastening!